

## **Triangle Research Collaborative, Inc.**

### **Editing Labs**

Although it is possible to have a lab setup that allows both recording and editing, some research teams prefer to do the editing in a different location. These are configurations designed to be used primarily for video editing.

The first three labs are portable editing labs. They can be easily transported from one room to another, or to a conference for a demonstration. Each of these three uses a slightly different setup. The first uses both a portable VCR and an editing VCR. The second uses a digital video camera and a digital editing VCR. Digital video allows cleaner images and edits than analog video. The third portable lab uses two editing VCRs. Editing VCRs are commercial-grade VCRs capable of positioning tapes at a specific frame in order to obtain crisp, precise edits.

Two of the portable labs have the option of using IEEE-1394 'firewire' to connect two digital VCRs or a camcorder and VCR. This wire enables video to travel directly between the two devices while the PC directly controls each machine.

The last two labs are stationary editing labs. The first one uses only one PC-VC card and two VCRs, while the second uses two cards and three VCRs. The top two VCRs are sources, and the bottom one is the target. This is useful when you want to do roll editing, in which you switch between two or more sources. For example, if you are taping the same event from two different angles and wish to make a demonstration or research tape combining shots from both angles, you could use roll editing.

These labs are merely examples of the designs we can do. If you would like more help in thinking about the kind of configuration you would need, or if you already have a lab in mind, contact TRC. We will be happy to help you construct the best possible lab for your needs.

### **TRC Contact Information**

Mailing: P.O. Box 12167  
Shipping: 100 Park Offices, Suite 115  
Research Triangle Park (RTP)  
North Carolina 27709-2167  
Phone: (919) 549-9093  
Fax: (919) 549-0493  
Email: [info@TRCtech.com](mailto:info@TRCtech.com)  
Homepage: <http://TRCtech.com>

# EDITING WORKSTATIONS

## Portable Video Editing Lab Configurations

### 1) Portable and Editing VCR

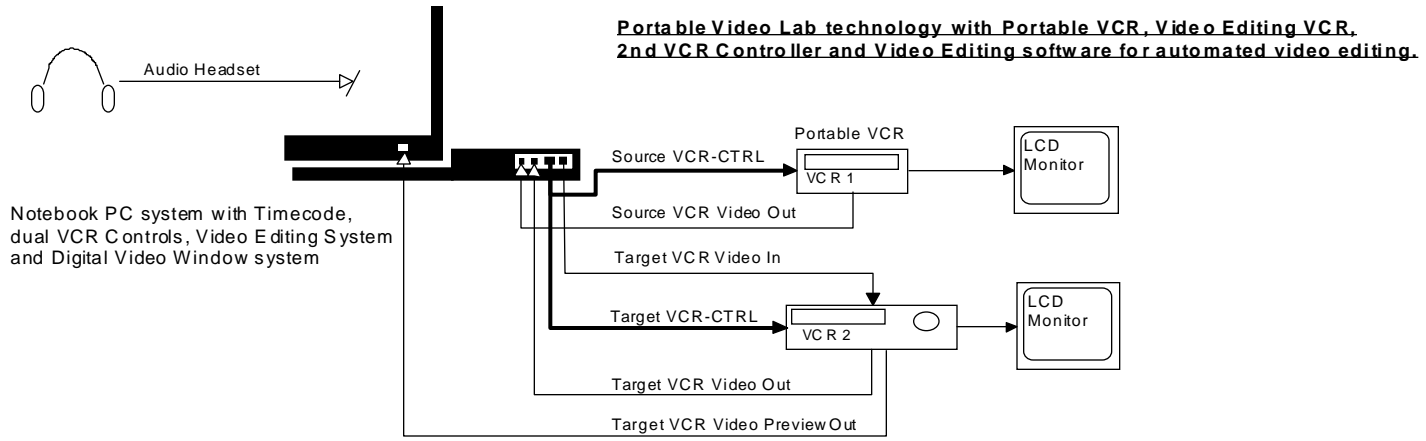

### 2) DVCamcorder and Editing VCR

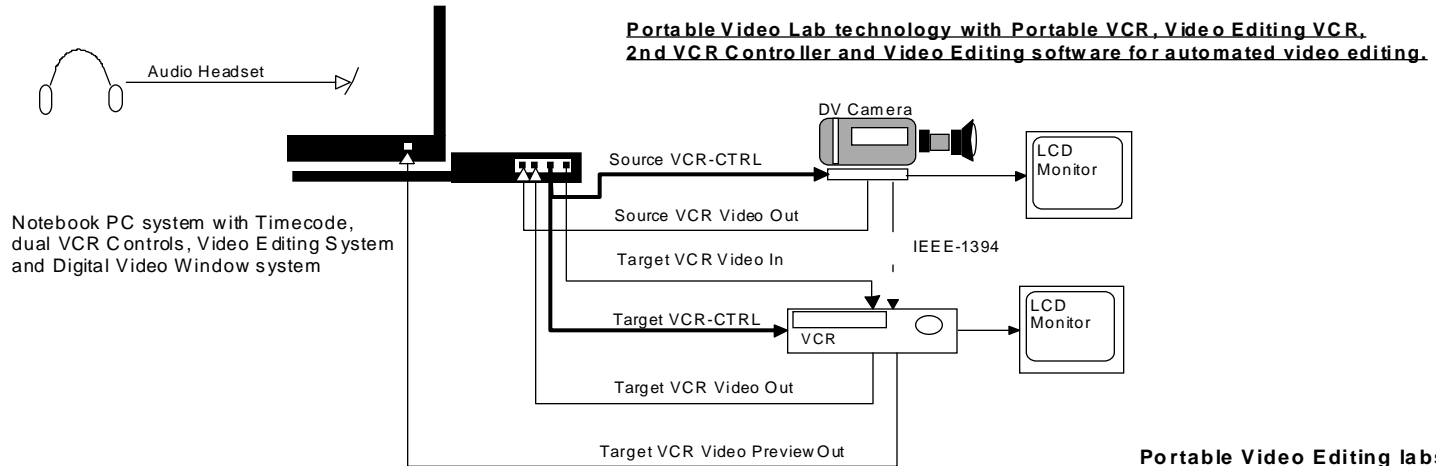

# EDITING WORKSTATIONS (CONT.)

## Portable Video Editing Lab Configurations (Cont.)

Portable Video Lab technology with two Editing VCRs, 2nd VCR Controller and Video Editing software offers fully automated video editing features.

### 3) Dual Editing VCRs

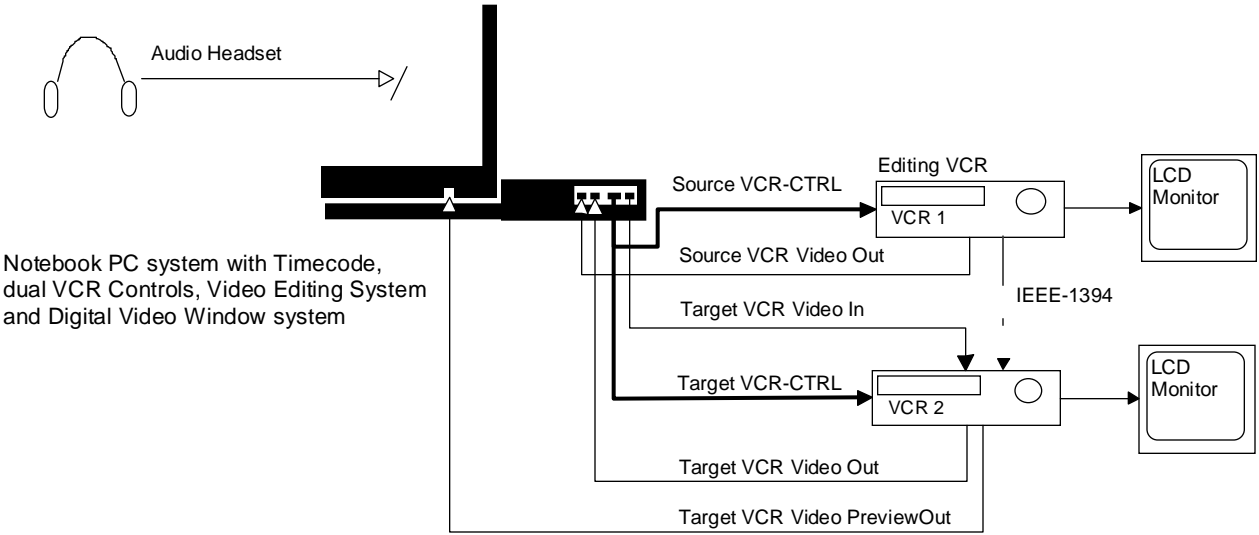

Portable Video Editing labs  
by Triangle Research Collaborative, Inc.

# EDITING WORKSTATIONS

## Synchronized Video Editing Labs

### 1) Single Card Editing Lab

Video Lab with Synchronized PC Workstation with PC-VC Card (w/VITC TimeCode Generator /Reader and VCR Control), Editing VCRs and VideoMonitors.

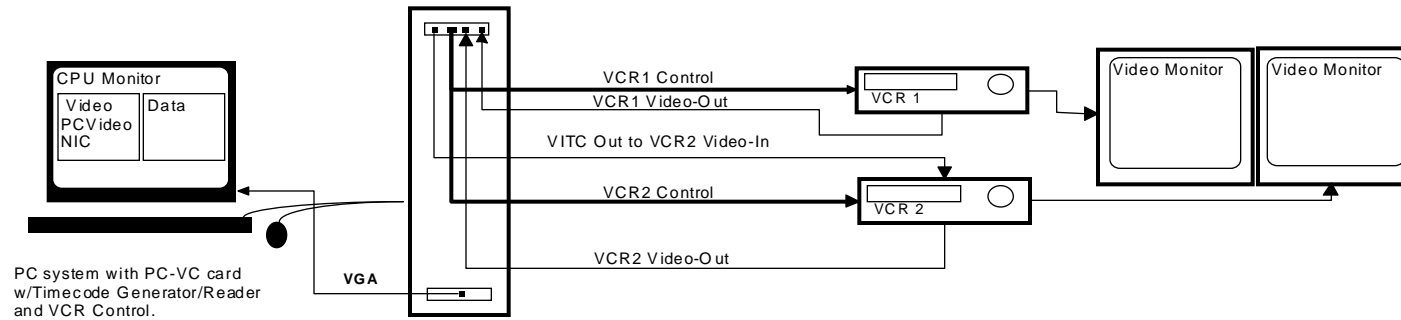

### 2) Dual Card Editing Lab (Roll Editing)

Video Lab with Synchronized PC Workstation with PC-VC Cards (w/VITC TimeCode Generators /Readers and VCR Control), Editing VCRs and VideoMonitors.

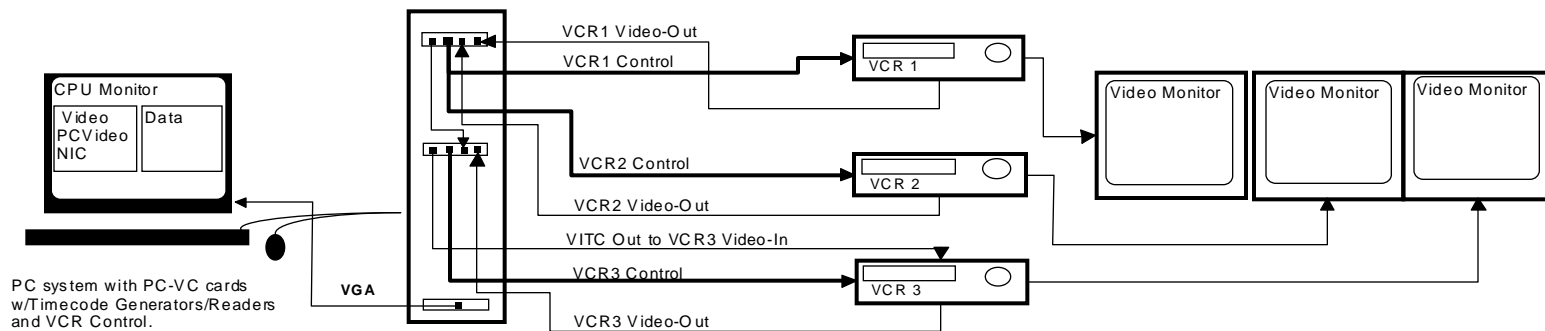

Synchronized Video Editing labs  
by Triangle Research Collaborative, Inc.